

KTD22.2-62

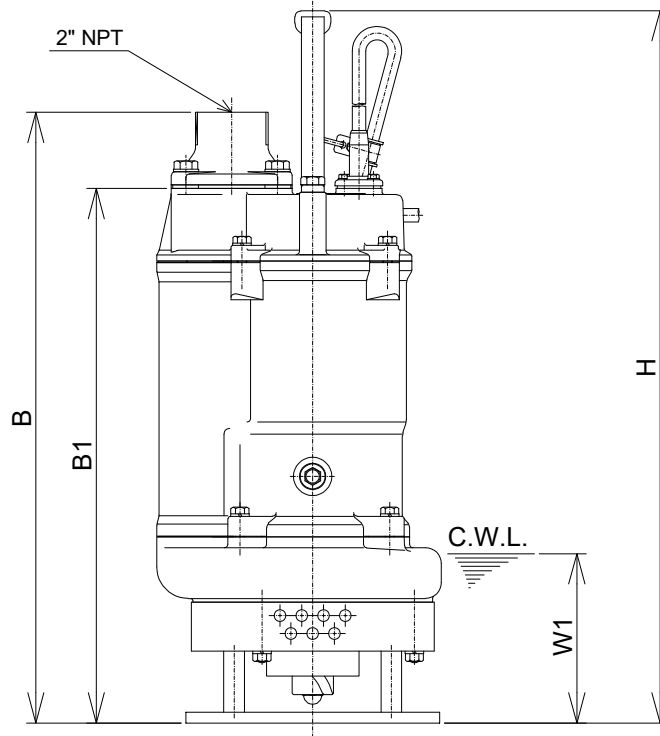
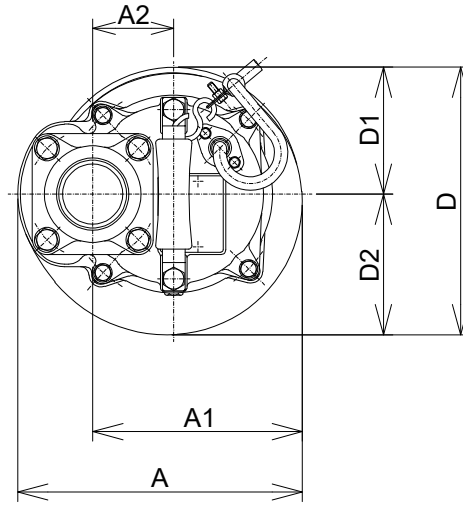

C.W.L. :Continuous running Water Level

DIMENSIONS:USCS (Inch)

Model	HP	NOM. SIZE	Pump & Motor									C.W.L.	*Wt.
			A	A1	A2	B	B1	D	D1	D2	H	W1	(lbs.)
KTD22.2-62	2.7	2"	9 1/4	6 13/16	2 5/8	19 7/8	17 3/8	8 11/16	4 1/8	4 9/16	23 3/16	5 1/2	84

DIMENSIONS:METRIC (mm)

*Excluding Cable

Model	kW	NOM. SIZE	Pump & Motor									C.W.L.	*Wt.
			A	A1	A2	B	B1	D	D1	D2	H	W1	(kg)
KTD22.2-62	2.0	50	235	173	67	505	442	221	105	116	589	140	38